



SYNChronize the material handling flow MECHANism to optimize resources

Pipe & Joint
Flexible Sytem

Belt & Roller
Conveyor

Material Handling
Equipment



Streamline Production Flow

Belt / Roller Conveyor

Power-Free Solution

JIT Warehouse System

Syncomech (Thailand) Co., Ltd.
บริษัท ซินโคเมค (ประเทศไทย) จำกัด





- Demand-based flow manufacturing
- Space-saving | Less Operating cost
- Zero energy consumption
- Stock control with FIFO
- Kanban Pull System
- Eliminating Muda



Pipe Structure		
	Goblin Pipe	Stainless Steel Pipe (SUS Pipe)
Materials	Steel Pipe (Cold Strip Steel Plate, SPCC-1, Thickness : 1.0mm) coated with ABS resin (thickness about 1mm)	Non-magnetic strong corrosion resistance High Grade Stainless Steel
Diameter of Pipes	28 mm (28 ϕ)	28 mm (28 ϕ)
Weight	About 725g / m	About 550 g / m
Colour	Ivory, Green, Blue, Black	Silver
Length of Pipe	4 m	4 m
Photo		
Structure		



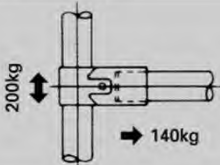

The Temperature for actual use of Goblin Pipe is limited within -10°C-80°C

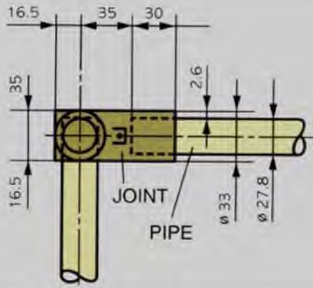
Other Pipe		
	Anti Static Dissipative ESD Pipe	Slide Pipe
Colour :	Black	Colour : Ivory
Function :	Design for ESD Safe Application	Function : Supports boxes for sliding
Standard Length :	4 meter	Standard Length : 4 meter
Photo :		Photo : 

The Strength of Pipe and Metal Joints			
	Testing Method	Load	Load
Goblin Pipe	- Centralized Loading - Loading speed : 1kg/minute - Temperature : Normal-10~80°C	 110kg	 200kg
Sus Pipe	- Horizontal Loading - Loading speed : 3kg/minute - Temperature : Normal	 192kg	 349kg
Metal Joint	- Tension load toward Vertical and Horizontal directions. - Tensile Speed : 5mm/m - Temperature : Normal	 200kg 140kg	

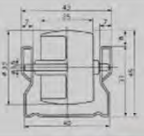
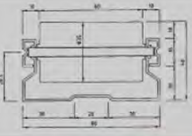
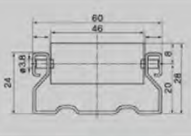
Joint Structure	
	Metal Joint
Materials	SPCC - 1 (2.6t)
Weight	About 82g a piece
Colour	Black, Silver
	

Placon

	Placon 40 Type	Placon 80 Type	Placon 60 Type
Materials-Frame	SPGI	SPGI	SPGI
Materials-Roller	PE	PE	PE
Roller Diameter	Ø33 mm	Ø35 mm	Ø16 mm
Roller Pitch	37 mm	37 mm	18.5 mm
Standard Length	4 m	4 m	4 m
Load Capacity-Per 1,000 mm of Placon Frame 	150	300	100
Structure			
Photo			

Basic Metal Joint (28 Ø) Length Calculation of Pipe

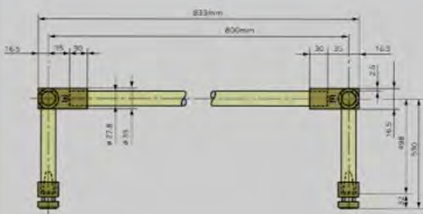

Horizontal Length Calculation

- 800 → From center length until center
- 70 → From pipe end length until center (35x2)
- 730 → Pipe cutting length

Vertical Length Calculation

- 530 → From bottom length until center
- 27 → From pipe end the metal parts hold the Length (space) which it does
- +16.5 → From joint center length until of joint outside
- 519.5 (520) → Pipe cutting length

Metal Joint For Pipe (28 Ø)

H-1  KT103-H001K	H-2  KW103-H002K	H-3  KW103-H003K	H-4  KT103-H004K	H-5  KT103-H005K	H-6  KT103-H006K	H-7  KT103-H007K
H-8  KW103-H008K	H-9  KM103-H009K	H-10  KW103-H010K	H-11  KW103-H011K	H-12  KW103-H012K	H-13A  KW103-H013AK	H-13B  KW103-H013BK
H-14A  KW103-H014AK	H-14B  KW103-H014BK	H-15  KW103-H015K	H-16  KW103-H016K	H-17  KW103-H017K		

Metal Joint (28Ø)

HJ-1

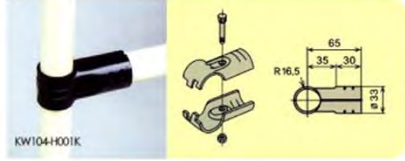

HJ-2



HJ-3



HJ-4



HJ-5



HJ-6

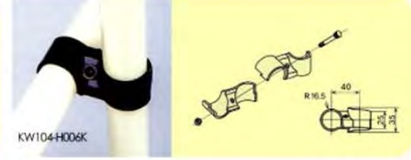

HJ-7



HJ-8



HJ-9

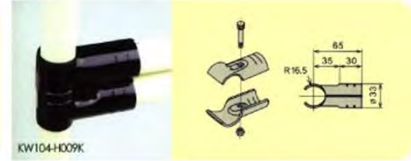

HJ-10



HJ-11



HJ-12

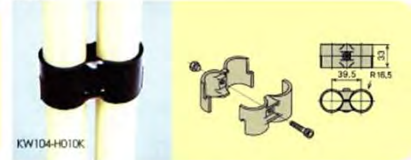

HJ-13

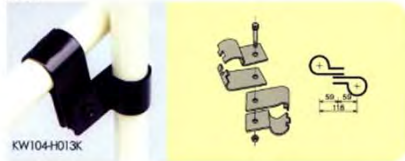

HJ-14

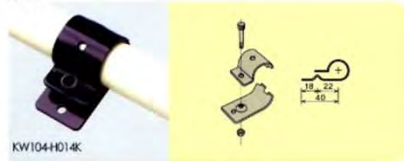

HJ-15



HJ-16



HJ-17



HJ-21



Placon Support Metal for 40 Type Placon

PLACON SUPPORT METAL-A



PLACON SUPPORT METAL-A1



PLACON SUPPORT METAL-B

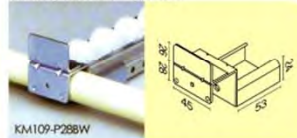

PLACON SUPPORT METAL-B1



PLACON SUPPORT METAL-C

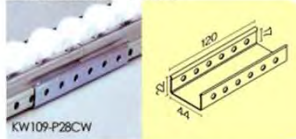

PLACON SUPPORT METAL-D



PLACON SUPPORT METAL-D1



PLACON SUPPORT METAL-E



PLACON SUPPORT METAL-40A (L)

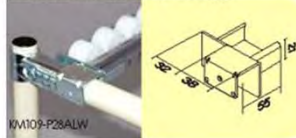

PLACON SUPPORT METAL-40A (R)



Placon Support Metal for 80 Type Placon

PLACON SUPPORT METAL-80A



PLACON SUPPORT METAL-80B



PLACON SUPPORT METAL-80B1



PLACON SUPPORT METAL-80C



PLACON SUPPORT METAL-80D



PLACON SUPPORT METAL-80D1



PLACON SUPPORT METAL-80E

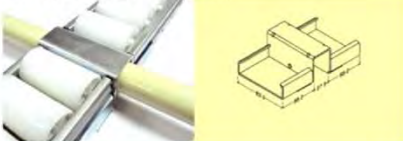

PLACON SUPPORT METAL-80A(L)



PLACON SUPPORT METAL-80A(R)



Placon Support Metal for 60 Type Placon

PLACON SUPPORT METAL-60A



PLACON SUPPORT METAL-60B



PLACON SUPPORT METAL-60B1

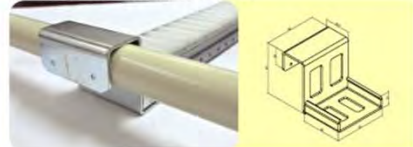

Accessories

SLIDE PIPE METAL-A



SLIDE PIPE METAL-B

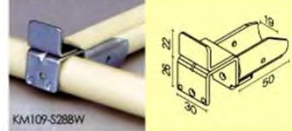

SLIDE PIPE METAL-B1

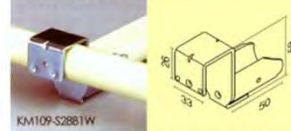

SLIDE PIPE METAL-C



CASTER SUPPORT METAL



SADDLE METAL-A



SADDLE METAL-B



SADDLE METAL-C



BOARD FIXING METAL-A



BOARD FIXING METAL-B



BOARD FIXING METAL-C



ROTATE METAL

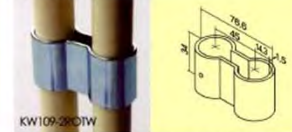

BOARD FIXING CORNER METAL-A



BOARD FIXING CORNER METAL-B



PIPE CONNECTING METAL FOR ABS PIPE

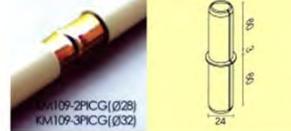

VERTICAL OPENING AND SHUTTING LINK METAL



OVERLAP CAP



LOCK METAL

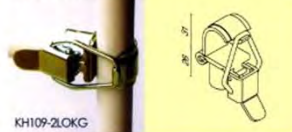

PIPE HANGING METAL



CORNER METAL



HANGING METAL-A

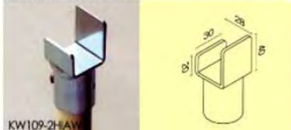

GUIDE METAL



TRACTING LINK METAL

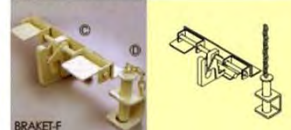

TRACTING LINK METAL

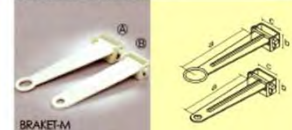

BRACKET-F



BRACKET-M



BRACKET-F



BRACKET-M

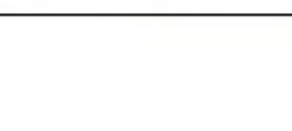

Plastic Accessories



Adjuster

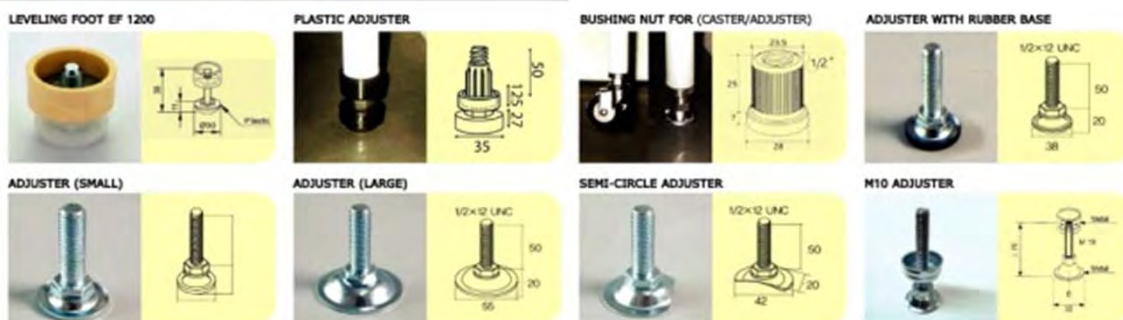

Caster

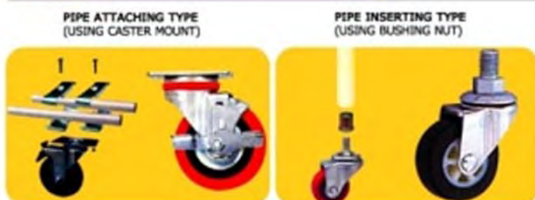

Ordering Guide

Wheel Size	Color	Wheel Material	Attach Type
2"	Grey	Rubber	Pipe Attached by using Caster Mount
2.5"	Black	Pressed Rubber	Pipe Insert by using Bushing Nut
3"	Red	Nylon	Direct Inserting Type
4"	ESD	Polyurethane	
5"		Eva	
6"		Cast Iron	

Pipe and Joint Application



Belt conveyor

Belt conveyor could be used as standard alone unit or in combination (as a system).

Wisely used in most of the industries such as electronic & electrical, food processing, paper & packaging and plastic injection moulding.



Roller conveyor

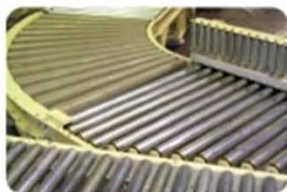

Free Roller Conveyor

Suitable table for decline or manually push application
Used as an economical alternative to powered conveyor
Commonly used in goods receiving and distributing,
Order picking, and work-in-process in general
Manufacturing environment

Chain Driver Roller Conveyor (Chain loop or chain tangential)

Conveyor rollers driven by loop or tangential of
Chain, engaging a sprocket attached to each driven
Roller, causing the roller to rotate
Zero pressure accumulation enabling the conveyor
To control and accumulate product as and when it
Required for further transport or processing

Line Shaft Driver Roller Conveyor

Conveyor rollers driven by polycord powered by a rotating shaft
Offer conveying of lighter weight products or back to back
Accumulation with very little pressure on the leading product
Commonly used in assembly and packing lines lines for

Pipe Cutter

- ✓ Designed to produce the finest cut possible
- ✓ Use less energy than ever
- ✓ High Performance bearing
- ✓ Improve cutting performance
- ✓ Replacement blade available



N30P 427830



Cutter wheel Roller

Ball Transfer



SYNCOMECH

Syncomech (Thailand) Co., Ltd.

บริษัท ซินโคเมค (ประเทศไทย) จำกัด

70/10 หมู่ 4 ถนนเทพารักษ์ ตำบลบางพลีใหญ่

อำเภอบางพลี จังหวัดสมุทรปราการ 10540

โทร/Tel : (662) 755 3604-5 แฟกซ์/Fax : (622) 755 3606

www.syncomech.com